

The STEYR IMPULS CVT with up to 200 hp

# BUILT **AROUND** YOUR FARMING



*Your partner to rely on.*

**STEYR**  
TRAKTOREN

# A TRACTOR WITH BODY AND **SOUL**

Our engineers racked their brains to design and build a compact, 6-cylinder tractor that can easily carry the weight of all your farm business.

## **The outcome: the IMPULS CVT, the tractor to count on**

The STEYR IMPULS CVT isn't a tool. It's your new partner. Even more so if your career is more of a calling than just a job. Available with a choice of high-performance six cylinder engines that deliver up to 200 hp (max unboosted), innovative S-Control™ CVT transmission, pneumatic suspended cab and much more, you're in good hands whatever the situation – leaving you free to put your heart and soul into your work.

» **Straight ahead. Made in Austria, to make the difference.**



04 – 05

**What's new**

---

24 – 25

**S front loader**

---

06 – 07

**IMPULS CVT  
at a glance**

---

26 – 29

**4WD and safety**

---

08 – 09

**Packages**

---

30 – 33

**S-TECH  
precision farming**

---

10 – 15

**Cab**

---

34 – 35

**S-FLEET telematics**

---

16 – 17

**Engine**

---

36 – 37

**STEYR service**

---

18 – 19

**S-CONTROL CVT  
transmission**

---

38 – 39

**Specifications**

---

20 – 23

**Front- and rear  
linkage area**

---



COMFORT BECOMES  
CONTROL, TECHNOLOGY  
BECOMES **EFFICIENCY**





#### **New premium comfort**

The STEYR pneumatic cab suspension is standard with Excellence package and delivers a premium comfort experience. Fatigue is reduced during long days in the field and on the road.



#### **New S-TRONIC custom settings**

Individually set-up your S-Control™ CVT transmission settings according to your operation.



#### **New logical layout**

Hitching up to implements is easy thanks to a logical layout. With a lifting capacity of over eight tons and ISOBUS III connectivity, the IMPULS CVT copes with every attachment.



#### **New – the perfect match**

Whether you're working around the farm yard or in the fields, the new STEYR S front loader series is the perfect match to your tractor and the challenges you face in your day-to-day work.

# MUCKS IN. WITH **PASSION**



Low noise level of 69 dB(A) for stress-free operation and for using the telephone.



Up to 20 LED-worklights for perfect 360° illumination.



Ergonomic operation using the Multicontroller armrest.



Dual-Motion driver seat, pneumatic cab suspension and front axle suspension for more comfort.



Powerful, efficient, ecological: the 6-cylinder engines from 165 up to 200 hp (maximum power) fulfill the Stage V emission standard.



S-TRONIC has been further advanced and offers customizable control features.



S-Control™ CVT: continuously variable transmission with ultimate mechanical efficiency rating.



50 kph achieved at a fuel-efficient 1,550 rpm.



Active hold control for stopping on a steep slope without a brake.



Headland management Easy-Tronic II for the automation of work operations, dependent on time and distance covered.



Three rear and 1,000 rpm front PTO speeds with Power mode or with the fuel-efficient engine speed of the ECO mode.



Maximum rear lift capacity of up to 8,257 kg and 3,568 kg at the front.



Patented trailer brake system S-BRAKE represents a major advance in tractor safety for the driver.



STEYR front loader ready. QuickTurn II full wheel lock at minimum steering movement especially for loader work.



Combinations of tyres and wheels to suit every type of application.



The IMPULS CVT supports ISOBUS II and ISOBUS III.



S-TECH precision farming: fully automatic turning with S-GUIDE and S-TURN II.



S-FLEET lets you remotely monitor and manage your farm, fleet and data.

STEYR

6175 IMPULS CVT



# IMPULS CVT ALL INCLUSIVE

## Well equipped

Your IMPULS CVT is available in three equipment configurations for convenience. Custom, for the a la carte approach, and Evolution and Excellence that configure the best IMPULS CVT options conveniently. You can quickly select the features that matter to you.

The equipment packages can be changed by STEYR without prior notification. Please contact your local dealer for the latest configuration.



## Evolution

### Evolution in comfort and performance for the customers

The front linkage is a standard feature with Evolution and allows you to quickly add and remove ballast and, for further productivity, add an additional mounted implement.



### » FACTS

- ▶ Electrohydraulic remotes and powerful hydraulic pump (140 l/min or 160 l/min optional)
- ▶ 3-speed PTO (540/540E/1,000 or 540E/1,000/1,000E)
- ▶ Electronic park lock is standard
- ▶ STEYR Deluxe or Active Luxury cab options with air conditioning, passenger seat & suspension
- ▶ Front linkage is standard (front linkage & PTO optional)
- ▶ Front axle suspension is standard
- ▶ S-TECH 700 Plus display is optional
- ▶ Standard steering or STEYR S-GUIDE autoguidance ready & variable ratio steering as optional
- ▶ ISOBUS Class II or III optional

## Excellence

### High-end performance and superior operator comfort features

The STEYR pneumatic cab suspension is standard with Excellence and delivers a premium comfort experience. Fatigue is reduced during long days in the field and on the road.



### » FACTS

- ▶ Electrohydraulic remotes with 160 l/min hydraulic pump as standard
- ▶ 3-speed PTO (540/540E/1,000 or 540E/1,000/1,000E)
- ▶ STEYR Deluxe or Active Luxury cab options with air conditioning & passenger seat
- ▶ Front linkage is standard (front linkage & PTO optional)
- ▶ Front axle suspension is standard
- ▶ S-TECH 700 Plus display is standard
- ▶ STEYR S-GUIDE autoguidance ready & variable ratio steering is standard
- ▶ ISOBUS Class II or III

# ENJOY **COMFORT** AND ERGONOMICS

## **IMPULS CVT comfort**

The slimline bonnet provides optimum visibility over the front working area. Also at the rear, for effortless attachment of implements, the IMPULS CVT provides clear visibility of the coupling points. With the large, electrically adjustable and heated telescopic mirrors with wide-angle insert, you can even keep an eye on wide attachments. An additional window in the roof provides unobstructed visibility of the front loader.

A new low mounted wiper increases the swept coverage area by 60% compared to previous models.



## Really good looking. At day and night

Perfect and unrestricted all round visibility – thanks to the 4-pillar panorama cab with its large windows, high-visibility roof window and one-piece front windscreen. The LED work light package assures superlative visibility even after night has fallen. Standard equipment comprises 6 LED work lights at the front of the roof, another 6 at the back of the roof, and 4 more LED work lights on the bonnet. An optional 4 LED work lights, one fitted low on each cab pillar, front and rear, are also available. The light intensity of 2,000 lumens per LED headlight turn night into day and ensure accurate, efficient work.

### » FACTS

- ▶ 4-pillar-cab
- ▶ Low noise level of just 69 dB(A)
- ▶ Sun roller blind on front and rear windscreen
- ▶ Up to 20 powerful LED worklights
- ▶ Front and rear mounted cameras for improved visibility when working with implements

## The perfect working place

The IMPULS CVT cab offers a working area you can rely upon fully in all situations: a low noise level of only 69 dB(A), ergonomic seating and steering wheel adjustments, finely adjustable air conditioning and a cab suspension, front axle suspension and Dual-Motion driver seat assure maximum comfort.

### » FACTS

- ▶ Low noise level of just 69 dB(A)
- ▶ Mechanical or pneumatic cab suspension
- ▶ Air condition or automatic climate control
- ▶ DAB-Radio with premium-loudspeaker
- ▶ Handsfree microphone
- ▶ Tablet and mobile mount with power sockets
- ▶ Plenty of storage compartments incl. a cool box



## DELUXE

---

- ▶ Dual-Motion driver seat with dynamic damping system
- ▶ Seat heating
- ▶ Swivel-mounted headrest
- ▶ Active carbon inserts to control humidity
- ▶ Leather steering wheel
- ▶ Carpet



## ACTIVE LUXURY

---

Difference compared to Deluxe

- ▶ Maximo-Evolution-leather driver seat
- ▶ Seat cooling
- ▶ Active-suspension with automatic adjustment
- ▶ Leather co-driver seat



# OPERATE YOUR IMPULS CVT **EXACTLY** HOW YOU WANT TO

## Well served

In the comfortable IMPULS CVT cockpit, you are in control. 12 freely programmable short cut menus allow quick access to key IMPULS CVT functions on the S-TECH 700 Plus monitor. Simple to access and even more convenient to set-up. At the centre of the STEYR Multicontroller armrest is the Intuitive Control Panel, a smart layout of key IMPULS CVT features that allows all drivers to get the best from the machine.



## 1 Free configurable

The STEYR Multicontroller handle features reconfigurable buttons that can be assigned via the S-TECH 700 Plus monitor. This allows you to control more of the IMPULS CVT and ISOBUS functions ergonomically in one hand.



## 2 Advanced loader joystick

Perfectly integrated, the advanced electronic joystick gives precise fingertip control with forward and reverse shuttle switch and transmission control. The joystick also comes factory ready for the integration of the third and fourth loader functions.



2

### » FACTS

- ▶ S-TECH 700 Plus: the integrated touchscreen colour monitor
- ▶ Ergonomic operation with Multicontroller
- ▶ Joystick and levers to control remote valves on front and rear
- ▶ Front and rear PTO switches
- ▶ ICP – Intuitive Control Panel
- ▶ ECO-Drive™ levers
- ▶ Hydraulic settings
- ▶ ISOBUS Aux-N

# GREAT POWER, **LOW** FUEL CONSUMPTION

## **Turbocharged six cylinder power**

Power used most intelligently. The engines in the IMPULS CVT models are the best in their class. Here, profitability, productivity, environmental preservation and ultra-modern energy management come together in perfect symbiosis. By virtue of the unique HI-eSCR2 exhaust gas after-treatment system, fuel consumption is optimised and power and engine response are improved. Optimum fuel injection time without exhaust gas recirculation means neither the engine nor the cooling system are overloaded. This makes maintenance intervals of 750 hours a reality. The system also does not require a particle filter, and this reduces maintenance costs.

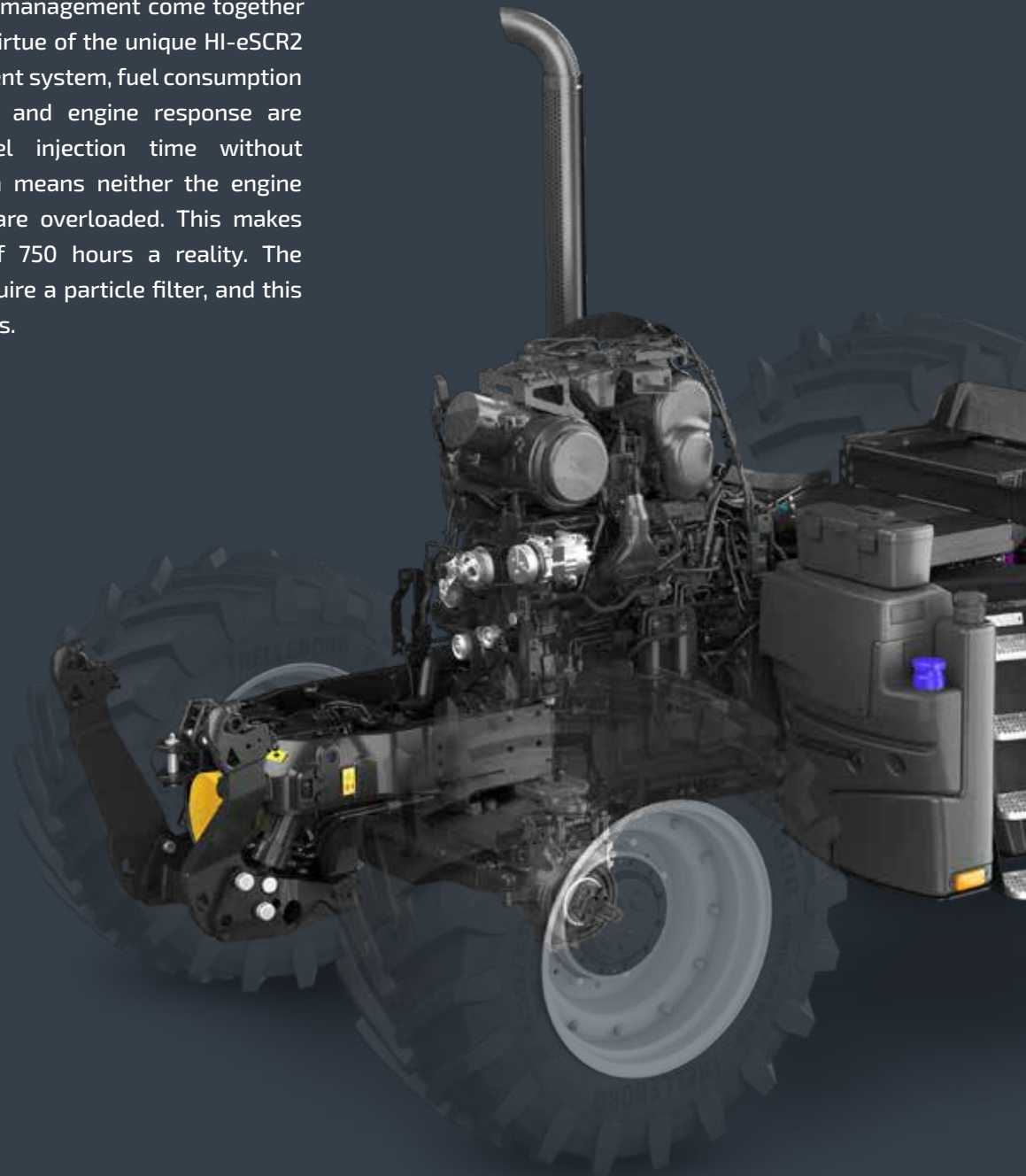



## ECO DRIVE

The dual hand throttle allows the individual adjustment of the minimum and maximum engine speed, adjusting the vehicle characteristics according to the required task and minimizing fuel consumption.

### 1 POWER MODE – Pulling and transport

Full potential of the engine is available.

### 2 ECO MODE – Pulling and transport economy

With the right hand throttle lever you can limit the maximum engine speed to save fuel.

### 3 PTO MODE

Set the desired engine (PTO) speed with the left hand throttle lever. The right hand throttle lever determines the engine speed down to which the engine can be drooped, before the transmission reduces the ground speed.

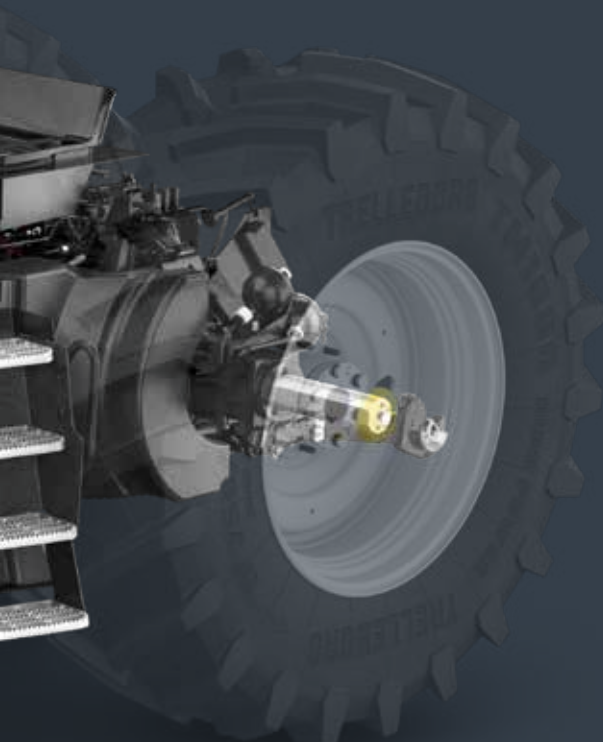

#### » FACTS

- ▶ 6-cylinder engines with turbocharger and intercooler
- ▶ 6.7 litre cubic capacity
- ▶ Rated power output: 150 – 180 hp. Max. power output: 165 – 200 hp
- ▶ High maximum torque with up to 940 Nm
- ▶ HI-eSCR2 technology from FPT fullfilis Stage V
- ▶ S-TRONIC engine and transmission management
- ▶ Engine is fully compatible with hydro-treated vegetable oil, or HVO (bio-synthetic diesel)
- ▶ Up to 46% torque increase
- ▶ Extended engine service intervals (750 hours)
- ▶ Reversible fan
- ▶ Engine exhaust brake
- ▶ 330-litre fuel tank to help maximise the working day

# TRUST IS GOOD. **S-TRONIC** IS BETTER

## **S-Control™ CVT transmission**

Maximum torque with minimum fuel consumption, electronic control that permits even faster changes in direction and active stationary control to stop safely on a steep gradient: the continuously variable S-Control™ CVT transmission is a leader in comfort and efficiency.

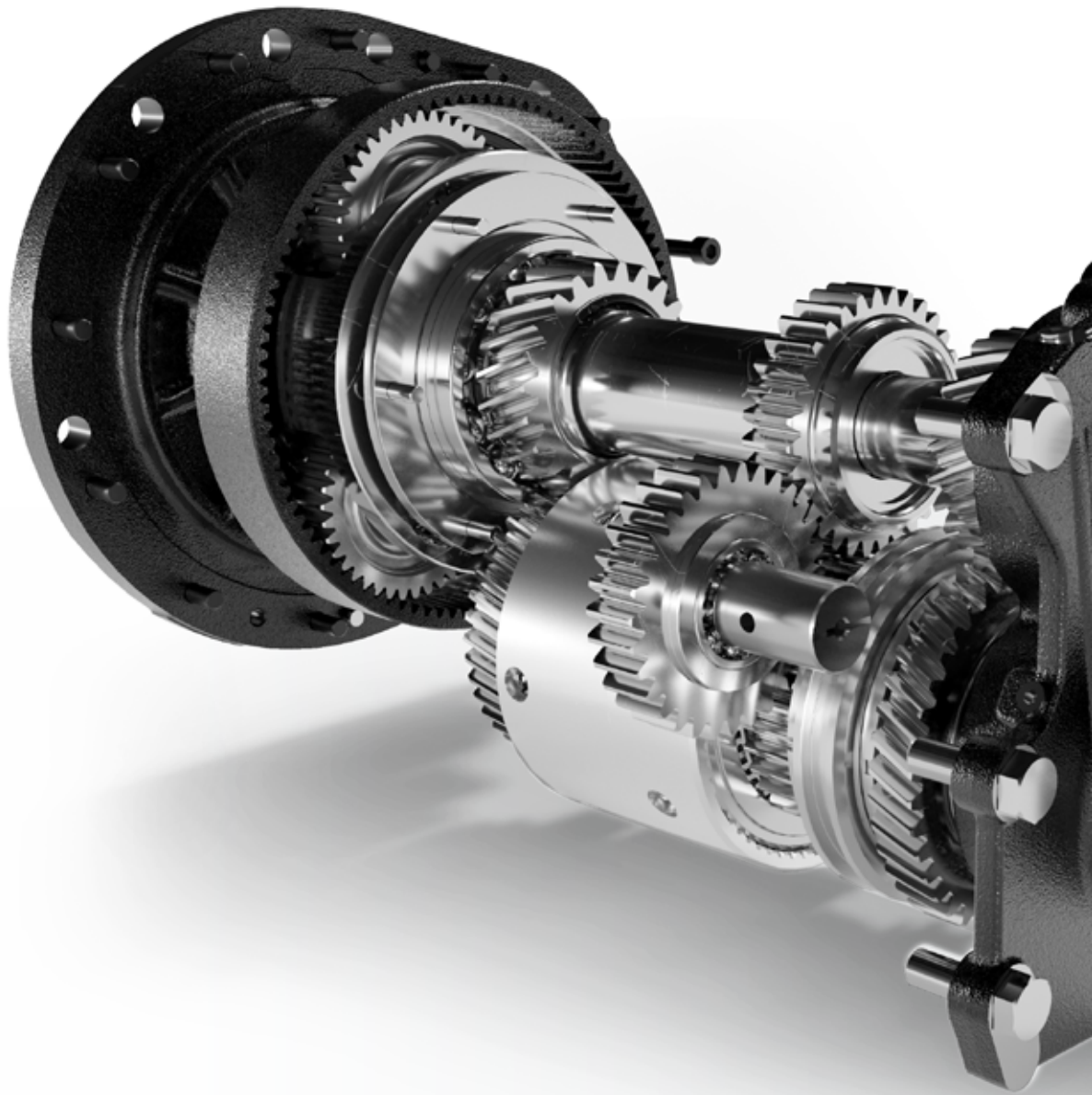

### S-TRONIC custom settings

Individually set-up your S-Control™ CVT transmission settings according to your operation.



### » FACTS

- ▶ Stepless from 0 to 40 or 50 kph
- ▶ 50 kph at reduced engine revs
- ▶ Two points of 100% mechanical efficiency
- ▶ Active hold control
- ▶ DKT – Double clutch technology
- ▶ Kick-down functionality
- ▶ S-TRONIC engine and transmission management
- ▶ CVT custom dynamics
  - Acceleration / deceleration
  - Shuttling speed
  - Drive pedal behavior
  - Engine torque response

# LEADING FROM THE FRONT. **AHEAD** IN HITCH/PTO

## Fully integrated

The STEYR front linkage has a lift capacity of 3,568 kg for the biggest of front mounted implements. The optional front PTO offers 1,000 rpm speed, this is achieved at an engine rpm of 1,895, the optimum range for power.

Attaching an implement is made safer and easier via easy-to-access remote hitch switches, and the optional camera provides an in cab view of the implement at work.

## FRONT LINKAGE

---

- ▶ 3,568 kg maximum lift capacity
- ▶ Seven-pin lighting and 40-A plug sockets fitted standard
- ▶ Remote operating switches for hitch operation to aid safe hitching



### **Better view**

The STEYR IMPULS CVT front camera is mounted directly above the front linkage and provides a wide degree of vision.



## FRONT PTO

---

- ▶ PTO perfectly integrated
- ▶ 1,000 rpm front PTO
- ▶ Front PTO-management
- ▶ Progressive soft start
- ▶ Electrohydraulic engagement under load

# HEAVY TASKS? MAKE THEM **LIGHT WORK**

## Always in good hands

The loadsensing hydraulic system of the IMPULS CVT is based on an axial piston variable displacement pump with an oil delivery rate of up to 160 l/min. Up to 8 independent valves can be supplied with oil at the same time. The delivery rate and duration can be set individually for each electrical remote valve. This guarantees an excellent response behavior for all connected implements.

Top links are by their nature heavy – connecting implements is easier with an improved top link fixing for better stability while a position indicator allows the operator to check from the seat. The rear PTO is available with three speeds.

## REAR HITCH

- ▶ Up to 8,257 kg lifting capacity
- ▶ Improved top link fixing for better stability and position indicator
- ▶ CCLS hydraulic system with up to 160 l/min pump capacity
- ▶ Electronic hitch regulation (EHR)
- ▶ Ride Control – dynamic vibration damping
- ▶ Up to eight electrohydraulic remote valves (five on the rear, three centrally mounted)
- ▶ Power-Beyond connection
- ▶ Easy setup through S-TECH 700 Plus monitor



### Easy setup

Shortcut keys bring you directly to the settings menu to configure your Multicontroller handle.

### Easy to reach

External controls on both fenders for easy implement connection.



## REAR PTO

---

- ▶ Electrohydraulic engagement under load
- ▶ PTO-Management
- ▶ Progressive soft start
- ▶ External controls on both rear fenders
- ▶ PTO-speeds: 540/540E/1,000 or 540E/1,000/1,000E



# THE **PERFECT MATCH** IS JUST IN FRONT OF YOU

## The new STEYR S series front loaders

Whether you're working around the farm yard or in the fields, the new STEYR S front loader series is the perfect match to your tractor and the challenges you face in your day-to-day work. Offered with premium specifications, you have the choice among 20 models across two ranges, compatible with an output of 58 to 240 hp and can be customized to cover the multiple application required for powerful handling tasks. The front loader mounting brackets and boom are perfectly designed to match your STEYR tractors, allowing easy access to all maintenance points without restricting your tractor's manoeuvrability.



Scan the QR-Code and get more information about STEYR S Series front loaders.



## U Range

### Versatility for everyday handling tasks

The versatile and durable U front loader range, with mechanical self-levelling, is ideal for everyday handling tasks. Easy-to-operate and robust, they are offered with the FITLOCK 2+ System® for quick hitching/unhitching and the MACH System® to safely connect all hydraulic and electrical lines. In addition, they feature an easy access to the 3<sup>rd</sup> function for implements requiring a hydraulic supply.

### » FACTS

- ▶ 3 models
- ▶ Lifting capacity: 2,412 kg to 2,728 kg
- ▶ Lifting height: 4.13 m to 4.58 m
- ▶ With or without mechanical self-levelling
- ▶ Optional 4<sup>th</sup> function

## T Range

### Performances with no compromises

If you need extra performance, the T range is tailor made for the highest demands with enhanced comfort. Designed to perform heavy-duty operations, the T range is equipped with the PCH hydraulic self-levelling linkage, which allows a large crowd angle, up to 52° at ground level, and increases the lifting power by 35% without needing any additional energy input. Which results into more amount of material on the bucket and less transport.

### » FACTS

- ▶ 4 models
- ▶ Lifting capacity: 2,486 kg to 3,261 kg
- ▶ Lifting height: 4.13 m to 4.60 m
- ▶ Hydraulic self-levelling PCM standard
- ▶ Hose and wiring harness are completely integrated in the boom and the crossbar



### » FEATURES

- ▶ FITLOCK 2+ System®
- ▶ MACH System®
- ▶ SHOCK Eliminator



### » FEATURES

- ▶ FITLOCK 2+ System®
- ▶ MACH System®
- ▶ SHOCK Eliminator
- ▶ FAST-LOCK System®
- ▶ AUTO-UNLOAD System®
- ▶ MACH 2®

# SAFETY, SECURITY, COMFORT. **AHEAD** ON ANY TERRAIN



## **Front axle suspension**

Ensures more comfort, better traction and safety.





#### **Wide trailer carriage**

Makes it easier to connect up the universal shaft to the PTO stub shaft.

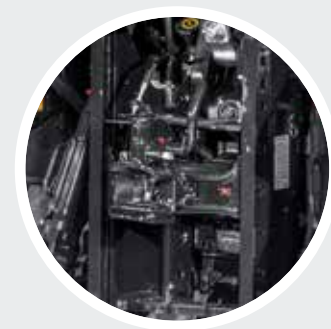

#### **Automatic trailer drawbar**

The towbar coupling is opened by remote control from the cab.



#### **K80 ball-head coupling**

Ideal for heavy-duty trailer operation.

## **Perfect traction**

With an excellent power-to-weight ratio and a high maximum permissible weight, IMPULS CVT tractors are strong in the field and on the road. The perfect interaction of all components ensures a unique driving experience of a new generation.

## **» FACTS**

- ▶ Automatic 4WD- and differential lock management
- ▶ Front axle suspension
- ▶ Various trailer fixtures for different transport operations
- ▶ Tyre and rim combinations for every application

# THE **ULTIMATE** IN SAFETY WHEN STOPPING FROM SPEED

## Perfect safe

The modern way of driving a tractor. The IMPULS CVT series offers the most complete braking system on the market with S-BRAKE trailer braking systems. All models are equipped with wet dual disc brakes (4 disc brakes on the rear axle). The more wear-resistant HD brake discs offer a longer service life, especially in heavy transport. The perfect interaction of all components ensures a unique driving experience of a new generation.



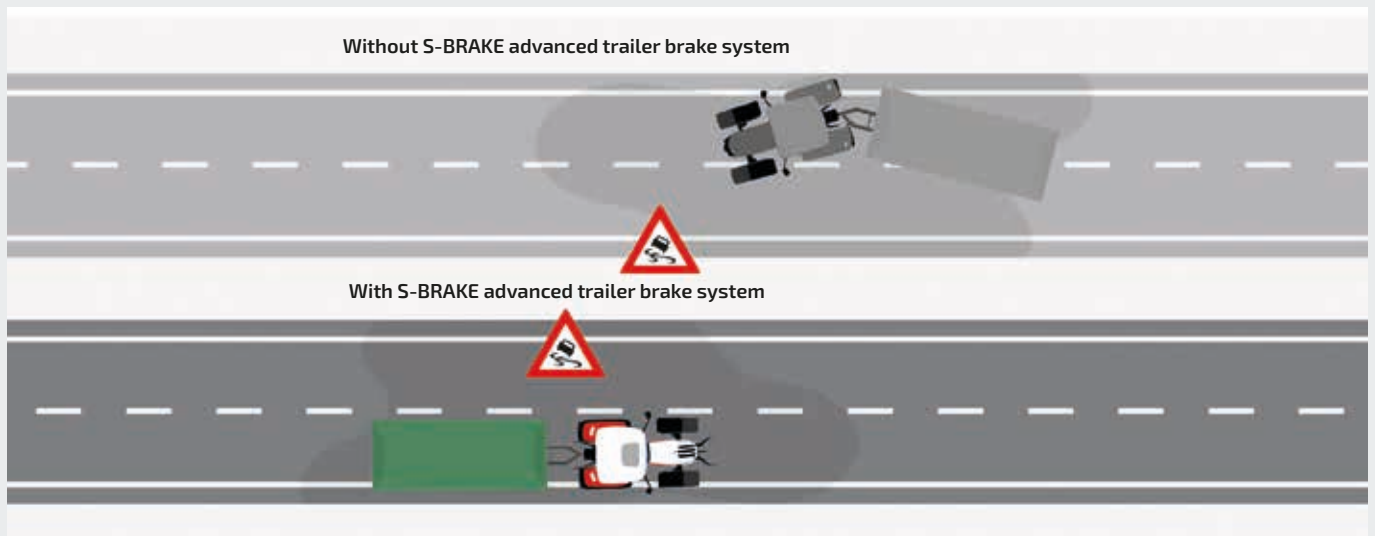

## Patented trailer brake system

With S-BRAKE, the advanced trailer braking system, you remain confident even in difficult situations. The patented system actively recognizes the current driving situation and stabilizes the combination when braking. The tractor and trailer stay in line.

### » FACTS

- ▶ All-wheel and 4-wheel braking
- ▶ Electronic parking brake
- ▶ S-BRAKE trailer braking system
- ▶ CTIS – Central tyre inflation optional

# ADVANCED, **EASY** **TO USE** TECHNOLOGY AT YOUR FINGERTIPS

## Up to 1.5 cm Track Precision

The automatic DGPS-based S-GUIDE steering system assures parallel tramline guidance for work in straight lanes, on curves and in the headlands. The system guarantees 100% network coverage and uses the revolutionary X-FILL technology to bridge signal losses lasting up to 20 minutes. With a precision of up to as little as 1.5 cm through an owned, comprehensive RTK+ network, there is no risk of overlapping even with tough ground or weather conditions.



### S-TECH 700 Plus & ISOBUS

The S-TECH 700 Plus touchscreen monitor offers an effective control and precision guidance system for arable farming. ISOBUS II-compatible attachments can easily be connected and controlled without additional wiring simply using the monitor.



## Lower your operation's input costs with section control

The technology will automatically switch sections on/off in areas that have already been covered to avoid overlap on passes in field, at headland turns and irregular fields shapes. This lowers your operation's input costs by eliminating double applications of seed and fertiliser.

### » FACTS

- ▶ Range of signal accuracies available (EGNOS, Range Point RTX, S-TECH 1, 2, 3 and S-TECH RTK+ signals)
- ▶ Optional high accuracy RTK+ signal with accuracy levels close to 1.5 cm
- ▶ X-FILL bridges RTK signal gaps of up to 20 minutes
- ▶ S-TECH 700 Plus monitor with touchscreen
- ▶ ISOBUS II and ISOBUS III compatible
- ▶ S-GUIDE is an integrated automated steering system
- ▶ S-TURN II automates turns at the end of a row

# AHEAD EVEN ON THE HEADLANDS

## Turn well. All good

The Easy-Tronic II headland management system is designed to relieve the driver as much as possible when turning on the headland and doing many other control activities. The S-TURN II technology in combination with Easy-Tronic II ensures complete automation of headland work. Steering processes, the turning radius, speed and control of the implements are automated and optimized at the headland. This leads to greater efficiency and increased comfort.

## EASY-TRONIC II AND S-TURN II

---

- ▶ Full automation of work sequences
- ▶ You can record and program while in operation or stationary
- ▶ Programming possible, dependent on time, distance and event initiation
- ▶ Calling up of sequences by Multicontroller, S-TECH 700 Plus monitor or on the ICP
- ▶ S-TURN II turns automatically at the end of a guidance line based on GPS position/boundaries
- ▶ ISOBUS Class II- and III-compatibility





## ISOBUS and IMPULS CVT

You can control ISOBUS Class II and III implements through the S-TECH 700 Plus monitor on the IMPULS CVT – potentially saving the need for a second display in the cab. With ISOBUS Class III, the implement can control certain IMPULS CVT functions, such as forward speed and hydraulics for example, thereby maximizing productivity and ensuring a consistent workflow process during long seasonal days.



# TECHNOLOGY TO KEEP YOU **AHEAD** OF YOUR WORK

## S-FLEET telematic solutions

S-FLEET lets you remotely monitor and manage your farm, fleet and data, allowing you to optimise your performance, productivity and flexibility. Efficiently visualise your equipment with little to no idle time. With all the information at your fingertips, you can successfully manage your operations anytime, anywhere!



**Keep an eye on your farm**  
Crop and weather monitoring  
Operation control in real time



**Keep an eye on your fleet**  
Machine tracking and monitoring  
On-time notifications



**Keep an eye on your data**  
Data sharing  
Connect with 3<sup>rd</sup> party partners

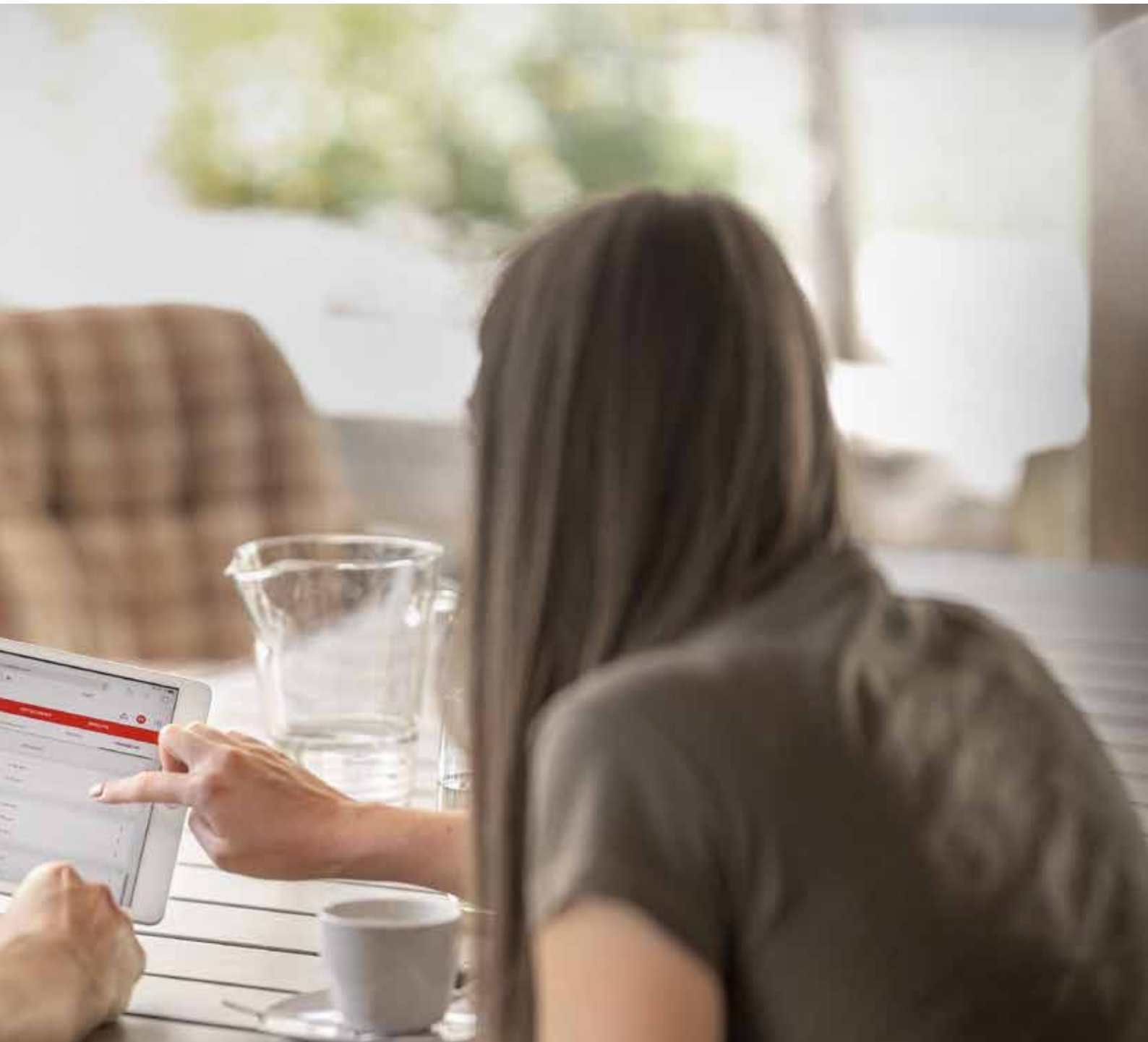

### Keep an eye on everything

Download the S-FLEET App and keep an eye on your operation anytime, anywhere!



One place to manage all your tractors as well as your equipment and devices.

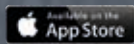

### » FACTS

- ▶ S-FLEET telematic solutions for maximum productivity
- ▶ User-friendly interface
- ▶ Time-saving management
- ▶ Data visualisation enhancing decision making
- ▶ Efficiently track your equipment's location and view machine parameters in real time
- ▶ mySTEYR is your destination for STEYR product support
- ▶ Solutions for mixed fleets – DataConnect

# ALWAYS THERE FOR YOU

Premium tractors deserve premium cares. No matter what you need, or what you may need. STEYR products and services are available and operating 24/7. Now and ever.

## STEYR PARTS

### QUALITY DOWN TO THE LAST DETAIL. STEYR GENUINE PARTS

Our certified Genuine Parts are designed for your STEYR tractor according to the exact specifications of our engineers and submitted to the most rigorous quality tests for conformity, robustness, safety and endurance. They last longer and perform better. Overtime. We work closely with our STEYR Dealers to ensure the availability and same day deliveries, saving you lengthy downtimes.

### THE VALUE ALTERNATIVE. STEYR REMAN PARTS

STEYR REMAN parts are the result of a thorough industrial process of disassembly, cleaning, treatment and re-assembly, which ultimately guarantees 100% reliability. That's why they also come with a 12-month warranty, saving you up to 30% compared to new parts. And respect the environment.

### UPGRADE YOUR TRACTOR. STEYR ACCESSORIES

With our accessories and kits, you can improve and customize your STEYR tractor to your own requirements – add a fuel preheater, additional headlights, rear cameras, control units and much more for an exclusive and efficient result.



## STEYR SERVICES

### TECHNICAL SUPPORT

STEYR Service experts, whether out in the field, at your dealer or on dedicated customer helplines, are ready to ensure quick and efficient solutions through their deep knowledge of STEYR equipment.

### ON SITE SERVICE

Specialized STEYR technicians are available to carry out maintenance and repair work on site or out in the field with a fully equipped Service van. These vehicles carry the latest electronic diagnostic tools and first-time fix kits.

### **/// PREMIUM SERVICE**

At STEYR, we have PREMIUM SERVICE, our customer support active 24 hours a day/7 days a week, no matter what you need. Call us on 080078397000 – the call is free. Working closely with STEYR dealer network, we offer a high level of customer care and provide fast feedback for any enquiry, from general information to Service assistance to reduce any downtime you might experience.

### **/// STEYR PROTECT**

STEYR PROTECT is the Manufacturer Extended Warranty program developed to protect your investment from unpredictable costs or machine downtimes. STEYR PROTECT is an extension of the Manufacturer Standard Warranty (first year) designed to support you with:

- Manufacturer warranty
- Best possible coverage
- Optimization of Total Cost of Ownership
- Enhanced profitability
- Higher residual value
- Transferable within the market

## SPECIFICATIONS

MODEL		6150 IMPULS CVT		6165 IMPULS CVT		6175 IMPULS CVT	
<b>TRANSMISSION</b>							
<b>S-Control™ CVT</b> Continuously variable transmission Driving speed* 0-50 kph or 0-40 kph ECO		●		●		●	
<b>ENGINE</b>							
<b>Common rail diesel engine</b> with HI-eSCR2 technology, 24 valves, turbocharger and intercooler, fulfills emission standards Stage V Number of cylinders / Capacity [cm <sup>3</sup> ]		6 / 6,728		6 / 6,728		6 / 6,728	
<b>Max. engine power</b> ECE R120 <sup>1)</sup> [kW/hp]	<b>Rated engine power</b> ECE R120 <sup>1)</sup> [kW/hp]	121 / 165	110 / 150	132 / 180	121 / 165	147 / 200	132 / 180
<b>Max. engine power</b> ECE R120 <sup>1)</sup> PowerPlus <sup>2)</sup> [kW/hp]	<b>Rated engine power</b> ECE R120 <sup>1)</sup> PowerPlus <sup>2)</sup> [kW/hp]	140 / 190	129 / 175	154 / 210	140 / 190	165 / 225	151 / 205
<b>Engine speed</b> at max. engine power [rpm]	<b>Rated engine speed</b> [rpm]	1,800 – 1,900	2,200	1,800 – 1,900	2,200	1,800 – 1,900	2,200
<b>Max. torque</b> with PowerPlus <sup>2)</sup> [Nm @ 1,500 rpm]		805		875		940	
<b>Max. torque</b> [Nm @ 1,500 rpm]		700		770		840	
<b>Torque increase OECD</b> Standard / PowerPlus <sup>2)</sup> [%]		46 / 44		46 / 44		46 / 44	
<b>Fuel tank</b> Diesel / AdBlue® [l]		330 / 48		330 / 48		330 / 48	
<b>PTO</b> <span style="float: right;"><b>Shifttable with progressive electro-hydraulic engagement with optional PTO management</b></span>							
<b>PTO speed</b> [rpm] 540 / 540E / 1,000 or 540E / 1,000 / 1,000E		● / ●		● / ●		● / ●	
<b>Engine speeds</b> [rpm] 1,969 / 1,546 / 1,893 or 1,592 / 1,893 / 1,621		● / ●		● / ●		● / ●	
<b>PTO shaft type</b>		1 3/8" 21-splines / 1 3/8" 6-splines					
<b>Front PTO</b> 1,000 @ 1,895 engine speed [rpm]		●		●		●	
<b>HYDRAULICS</b>							
<b>EHR hitch control</b> with dynamic vibration damping Ride Control		●		●		●	
<b>Max. pump flow rate</b> with pressure/volume control, load Sensing	140 L/min	●		●		●	
	160 L/min	●		●		●	
<b>Max. operating pressure</b> [bar]		210		210		210	
<b>Max. lifting capacity</b> [kg]		8,257		8,257		8,257	
<b>Remote valves</b>	<b>rear, up to 5 electrical can be configured</b>	●		●		●	
	<b>midmounted, up to 3 electrical</b>	●		●		●	
<b>Hydraulic linkage</b> Cat II/III with high-speed tail hook		●		●		●	
<b>Integrated front hitch*</b> max. lifting capacity [kg]		3,568		3,568		3,568	

MODEL		6150 IMPULS CVT	6165 IMPULS CVT	6175 IMPULS CVT
<b>ALL-WHEEL DRIVE</b>				
<b>Engagement</b> electro-hydraulic with traction management		•	•	•
<b>FRONT AXLE STEERING</b>				
<b>Suspended front axle</b>		•	•	•
<b>Steering system</b> Hydraulic, load-sensing system		•	•	•
<b>Steering wheel</b> Height- and tilt-adjustable		•	•	•
<b>Steering angle</b> Track width <sup>3)</sup> 1,829 mm [°]		55	55	55
<b>Min. turning radius</b> Track width <sup>3)</sup> 1,829 mm [m]		5.45	5.45	5.45
<b>BRAKES</b>				
Wet dual brake discs, hydraulically actuated		•	•	•
All-wheel brake with Opti-Stop		•	•	•
Two-line compressed air braking system		•	•	•
S-BRAKE patented trailer brake system		•	•	•
<b>TYRES</b>				
<b>Maximum tyre size<sup>4)</sup></b>	Front	600/65 R28	600/65 R28	600/65 R28
	Rear	710/70 R38	710/70 R38	710/70 R38
<b>WEIGHT</b>				
<b>Approximate shipping weight*</b> Standard / Suspended front axle [kg]		6,480 / 6,782	6,480 / 6,782	6,480 / 6,782
<b>Permissible total weight [kg]</b>		11,500	11,500	11,500
<b>DIMENSIONS<sup>3)</sup></b>				
<b>Max. length</b> with front and rear lower links down [mm]		5,316		
<b>Min. width</b> across rear fenders – narrow / wide type fender [mm]		2,060 / 2,476		
<b>Total height [mm]</b>		3,026		
<b>Wheelbase [mm]</b>		2,789		
<b>Min. – max. track width front [mm]</b>		1,325 – 2,285		
<b>Min. – max. track width rear [mm]</b>		1,430 – 2,230		

• Standard    • Optional    – Not available

\*Depending on country-specific legislative requirements and specifications

<sup>1)</sup> ECE R120 complies with ISO 14396 and 97/68EC

<sup>2)</sup> Power Plus is available on the basis of defined prerequisites for transport operations and PTO operation

<sup>3)</sup> With standard tyres

<sup>4)</sup> Other tyres available as special equipment on request (i.e. as cost options)



You drive better when you are safe. Before using this vehicle, please read the Operating Manual and become familiar with the use of each of the controls. Note the contents of the instruction panels and use the safety equipment for your own personal safety. This brochure is intended for use internationally. The availability of a few models and of standard and special equipment items may vary from one country to another.



STEYR reserves the right at any time and without prior announcement to make changes to the design and technical version without this in any way obliging STEYR to transfer these to units already sold.

Details, descriptions and pictorial material reflect the current status at the date of publication, but can be amended without prior announcement and at any time. Pictorial materials may show certain national versions, items of special equipment as well as non-complete standard versions.

TP01 / SM / 12.22 / Printed in Austria – Cod. n. 2250047COMINB  
[www.steyr-traktoren.com](http://www.steyr-traktoren.com)

[steyr-traktoren.com](http://steyr-traktoren.com)



**STEYR**  
TRAKTOREN